

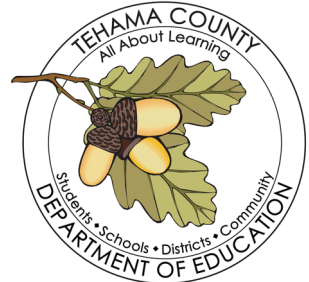

Technical Coaching Assistance Grant

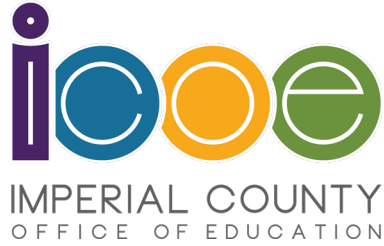



Welcoming Activity

**“Lean on me, when you’re not strong
And I’ll be your friend, I’ll help you carry on
For it won’t be long, til I’m gonna need
Somebody to lean on.”
-Bill Withers**

In the Chat:

**Describe how you feel/felt after leaning on someone
for support or wisdom?**



Statewide Coordinator

The goal for the Statewide Coordinator is to collectively develop a range of strategies to build the capacity for comprehensive student mental health systems.

The Statewide Coordinator will:

- Act as project lead and subject matter expert for statewide technical assistance for Mental Health Student Services Act grantees working in collaboration with the Technical Coaching Teams and the Commission.
- Establish statewide and/or regional technical assistance learning collaboratives for interested grantees.
- Develop and maintain a centralized webpage to receive and share information and resources with TCTs and MHSSA grantees.



More information coming soon!



With **PURPOSE**, comes **GOALS**...

- **Immediate Goal:**
 - Provide technical assistance to all MHSSA Grantees on a statewide basis
- **Accomplished by:**
 - Conducting grantee needs assessment
 - Individualized technical assistance support and direct consultation to other MHSSA Grantees
 - Support of a web-based information hub to be developed by third-party Statewide Coordinator
- **Grantees requesting Technical Coaching will be connected to:**
 - A **Technical Coaching Team Member** or **Lead** working with the **Statewide Coordinator** to build the capacity for excellent student mental health programs throughout the state.



DELIVERY MODEL

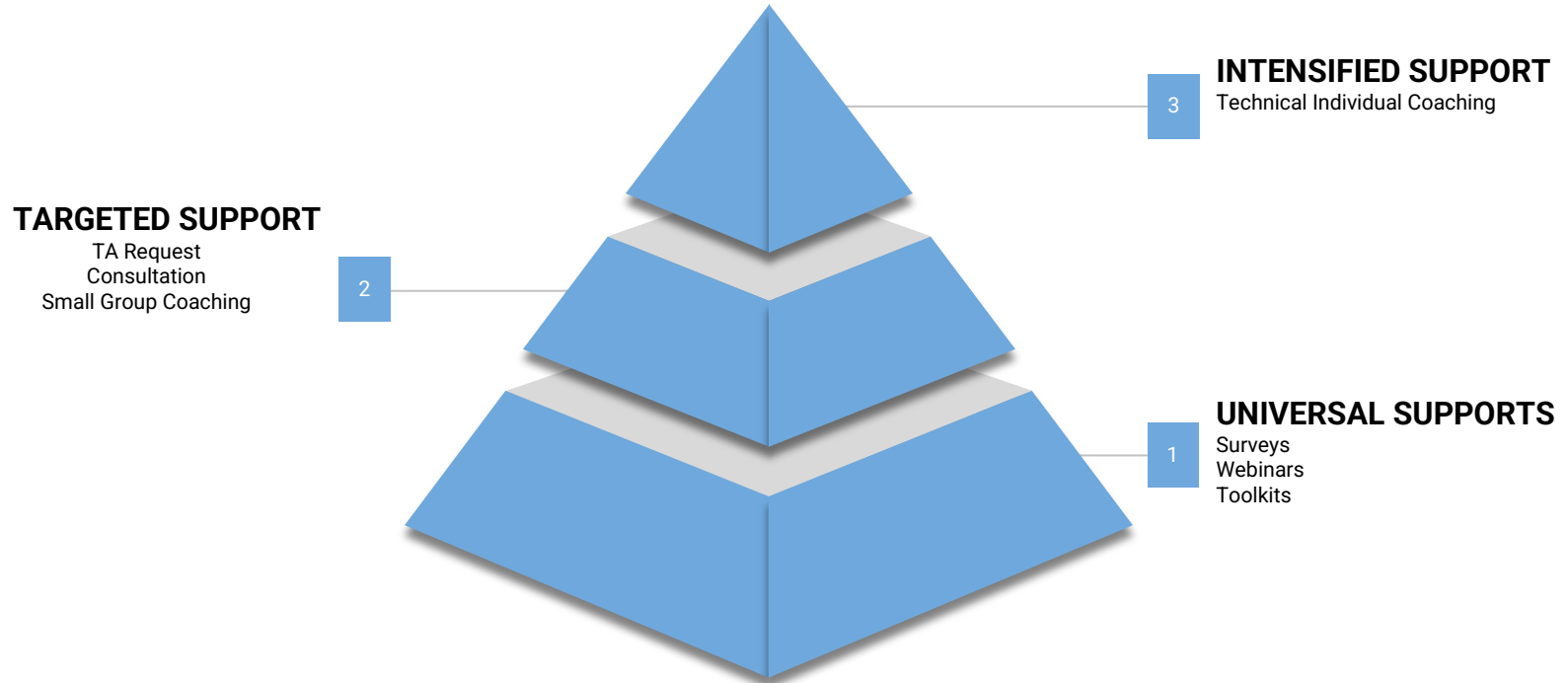



Get to Know Your TCTs!

- **Technical Coaching Teams**

- Provided in **FOUR distinct content areas**
- By **THREE** different MHSSA grantee counties.
- Subject areas were identified by the MHSOAC (Commission) as creating barriers to success for MHSSA programs.

Data Collection

Tehama County
Department of Education

Sustainability

Imperial County Office of
Education

Program Implementation

Placer County Office of
Education

Partnership Development

Imperial County Office of
Education

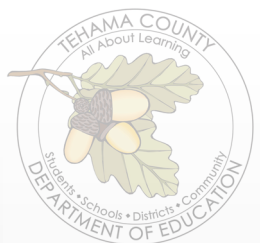
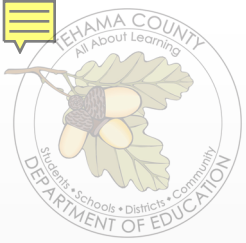

Data Collection

Tehama County Department of Education



JoNell Wallace

Mental Health &
Wellness Coordinator



Sara Smith

Assistant
Superintendent



Logan Smith

Project
Consultant



Data Collection

Technical Assistance topics include but are not limited to:

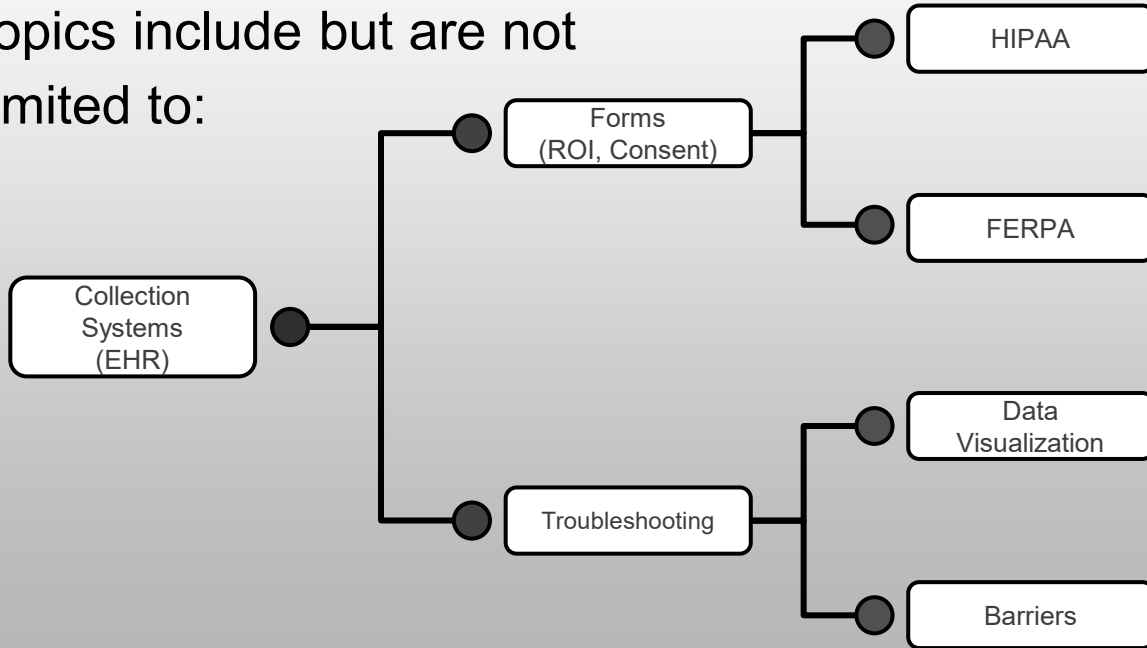

Partnership Development

- Strategies to **identify and engage partners** including school districts, county behavioral health, county public health, families, and other community based organizations
- Development and establishment **systems of communication** to ensure a consistent venue to share information
- **Strategic planning** through needs assessments
- **Tool Kits** including sample MOUs, Data Sharing Agreements, etc.





Program Implementation

POSITIVE BEHAVIORAL INTERVENTIONS AND SUPPORTS

ROOTS

PULPITI COUNTY OF EDUCATION



Allison (Ali) Murphy, LMFT
Director, Mental Health



Rio Poliquin, LCSW
Program Manager,
Mental Health



Christina Trentz, LMFT
Coordinator
Community Schools &
Integrated Supports



PROGRAM IMPLEMENTATION

Frameworks to build
efficient systems



Implementation Tools
and Resources



Consultation for “every
day” challenges



Translating the languages of
schools, counties, and community



Sustainability



Technical Assistance topics; including, but not limited to:

- Alignment of different funding streams, and blending and braiding of funding sources
- How local partnerships encourage sustainability efforts
- Local Educational Agency (LEA) Medi-Cal Billing Option Program (BOP)
- Partnering with private insurance companies
- Student Behavioral Health Incentive Program (SBHIP)



Miriam Belopolsky, ICOE
M.A. PPS, School Counseling



Let's Hear from Some of Our Friends...



- **El Dorado COE**
- **Tuolumne COE**

TA with TCTs

1. Grantees submit a request for TCT via our [Technical Assistance Request Hub](#)
2. A member of the TCT Team will reach out to schedule/confirm a Zoom Meeting within a week.
3. What to expect:
 - Discussion and thought partnership
 - Resource sharing
 - Data observation and review
 - Best Practices
4. An important note:
 - Potential for an additional meeting with the larger MHSOAC RED Team if your request involves data analysis, issues with the data collection tool, or evaluation
 - May also connect to other TCT
5. [Exit Survey will be sent out following TA](#)





Upcoming Opportunities

- Office hours
- Web Hub for all TA
- Calendar of Events
- Analysis of Needs Assessment and Targeted TA through a tiered system of support





Help Us, Help You... Needs Assessment



Click or Scan!



Long Term Goal ~ If It All Goes Right

To **SUSTAIN** the county partnerships that were formed for the purpose of MHSSA grant funding, and to support the ongoing **DELIVERY** of behavioral and mental health services for children and youth at readily **ACCESSIBLE** sites.

